

INSTRUCTION MANUAL

PORTABLE MAGNETIC DRILLING MACHINE

Read this manual carefully before operating your Nitto Kohki Portable Magnetic Drilling Machine. Keep this manual with your machine. All users of the Nitto Kohki Portable Magnetic Drilling Machine must read this manual.

ATRA ACE Model WA-3500

Professional Tool

For One-Touch Type Annular Cutter Only
(Side-Lock Type Annular Cutter cannot be used.)



Specifications

Model		WA-3500
Power Supply (Single Phase)		220-240 V ~ 50/60 Hz
Drill Motor	Rated Power Consumption	1100 W
	Rated Current	5.1 A
	No-load Speed	950 min ⁻¹
	Load Speed	580 min ⁻¹
Magnet Power Consumption		34 W
Hole Capacity	JETBROACH One-touch type	φ 17.5 ~ φ 35mm Plate thickness 35mm(50mm)
	HI-BROACH One-touch type	φ 14 ~ φ 35mm Plate thickness 25mm(50mm)
Magnet Holding Power		7,056N
Magnet Dimensions		92mm × 213mm
Weight		20kg
Short-Circuit Current Rating		5kA

The specifications and configurations contained in this document are subject to change without prior notice due to improvements we are making day in, day out.



Manufactured by :

NITTO KOHKI Co., Ltd.

2-9-4, Nakaikegami, Ohta-ku,
Tokyo, 146-8555, Japan

Tel : (81)-3-3755-1111

Fax : (81)-3-3753-8791

E-mail : overseas@nitto-kohki.co.jp

URL : www.nitto-kohki.co.jp

Keep the manual handy – so you can use it whenever necessary.

Original Instructions

TQ12846-6

Thank you very much for your purchase of **Nitto Kohki product**.

Before using your machine, please read this manual carefully so that you may use it properly to get the most out of it.





Please keep the manual handy - so you can use it whenever necessary.

- English :Please ask your dealer or distributor for instruction manual in local language(s).
- German :Bitte fragen Sie Ihren Händler nach eine Betriebsanleitung in Landessprache.
- French :S'il vous plait, veuillez demandez à votre fournisseur de manuel instruction en langue locale.
- Spanish :Por favor, contacte con su distribuidor para el manual de instrucciones en español.
- Portuguese :Por favor pessa ao seo agente ou distribuidor o manual de instrucces ih linguagen local.
- Italian :Per Manuale Istruzioni in lingua locale Vi preghiamo di rivolgervi al rivenditore o distributore.
- Dutch :Vraag uw handelaar om een nederladstalige gebruiksaanwijzing.
- Swedish :Be er lokala Åtreförsäljare eller distributör om manualer på svenska.
- Danish :Venligst henvend Dem til den danske distributør for instructions manualer.
- Polish :Proszę pytać swojego dealera lub dystrybutora o instrukcje obsługi w języku localnym.
- 中文 :請向當地供應商或經銷商詢問中文使用說明書

CONTENTS



GENERAL SAFETY RULES	2
POWER TOOL SAFETY	3
ABOUT YOUR NITTO PORTABLE MAGNETIC DRILLING MACHINE	4
1. APPLICATION	7
2. RECEIVING INSPECTION	7
3. PART NAME	8
4. FUNCTIONS OF ELECTRONIC CONTROL	9
5. MACHINE SETUP	9
6. MACHINE OPERATION	11
7. TROUBLESHOOTING.....	14
8. MAINTENANCE/SERVICE	15
9. OPTIONAL PARTS	16

PICTOGRAM

	Using this tool improperly could result in serious injury. Read the instruction manual before using.
	Do not allow the main body or the power source to get wet as it will cause electric shock and leakage.
	Always wear suitable eye protection.
	Always wear suitable hearing protection.
	Always wear respiratory protective equipment (PPE).

- Sound Pressure Level :Maximum 85dB(A) according to Clause 1.7.4(f), Annex I, Machinery Directive.
- Sound Power Level :Maximum 98dB(A)
- Operating Temperature :5°C ~ 40°C
- Operating Humidity :Maximum 90% at 25°C
- Over-voltage Category :Category II according to IEC664-1
- Pollution Degree :Degree 3 according to IEC664-1
- Wiring Diagram No. :TZW0055

The following Safety notations are used throughout the manual to highlight safety precautions for the user and for the machine.

 DANGER:	Indicates an imminently hazardous situation which, if not avoided by following the instructions given, will result in death or serious injury.
 WARNING:	Indicates a potentially hazardous situation which, if not avoided by following the instructions given, could result in death or serious injury.
 CAUTION:	Indicates a potentially hazardous situation which, if not avoided by following the instructions given, could result in injury or material damage.

Caution: Important precautions for machine or tool setup, operation and maintenance.

WARNING

Some dust created by power sanding, sawing, grinding, drilling and other construction activities contains chemicals known [to the State of California] to cause cancer, birth defects or other reproductive harm. Some examples of these chemicals are;

- Lead from lead-based paints.
- Crystalline silica from bricks and cement and other masonry products.
- Arsenic and chromium from chemically-treated lumber.

Your risk from these exposures varies, depending on how often you do this type of work. To reduce your exposure to these chemicals; work in a well ventilated area, and work within approved safety equipment, such as those dust masks that are specially designed to filter out microscopic particles.

GENERAL SAFETY RULES

TO OPERATORS

Always Wear Proper Clothing

- Do not wear loose clothing. Loose clothing can become caught in the drilling machine. This could cause severe injuries. Be careful that loose clothing does not come into contact with the machine.
- Wear non-skid footwear. If you lose your footing, you could contact moving portions of the machine. This could cause severe injuries. Always wear non-skid footwear and remain balanced when using the drilling machine.
- Be careful of long hair. Wear a hat or a hair net to contain long hair. Long hair can become caught in the drilling machine. This will cause severe injuries. Be careful that long hair does not come into contact with the drilling machine.

Always Wear Suitable eye protection

- Always wear Suitable eye protection. The operation of your drilling machine will cause flying chips and particles. These will cause severe eye injuries. You must always wear Suitable eye protection.
- Not all glasses are Suitable eye protection. Wear only Suitable eye protection that comply with ANSI standards. Not all of the lenses are shock resistant. Ordinary glasses will not provide sufficient eye protection.

Always Wear Suitable Hearing Protection

- Always wear Suitable hearing protection. The operation of your drilling machine will cause big sound occurs. These will cause severe hearing loss injuries. You must always wear Suitable hearing protection.

Wear respiratory protective equipment (PPE)

- Wear respiratory protective equipment (PPE) when working in an environment where dust particles are generated in operation.

Maintain Good Posture

- Always wear non-skid footwear and maintain good posture. Do not use the drilling machine when you are tired. Fatigue or loss of balance could cause you to lose control of the machine. This could cause severe injuries. Always stay balanced. Always keep good posture. Stop using the machine if you are tired.

Never Touch the Cutting Tip

- Never touch the moving or cutting tip. Contact with the moving tip will cause severe injuries. Always keep all parts of your body away from the cutting tip. Always keep your hand and clothing away from the cutting tip.

ABOUT THE WORK AREA

Keep Work Area Clean

- Always keep your work area clean. Cluttered work areas cause accidents. Always keep clear of other objects.
- Never use the magnetic drilling machine when it is wet. Always use the drilling machine in a dry area. Do not use the drilling machine in the rain. If you use the machine when it is wet you can get electric shock. If you use the machine in the rain you can get an electric shock.
- Always use the drilling machine in a well-lighted area. Do not use the drilling machine in the dark.
- Avoid all flammable materials. Use of the drilling machine may cause a spark that could ignite a fire or an explosion. Never use the machine near any flammable material.
- Keep away from children. Always keep the drilling machine away from children. Do not operate drilling machine when children are present.

BEFORE OPERATION

Make sure that all parts are free from damage

- Make sure that the drilling machine is in good operating condition. Operation of a damaged machine could result in severe injuries. If there is any damage to the machine, do not use the machine. If there is any damage to the machine, take it to an authorized Nitto dealer for repair.
- Do not attempt service or repair of the drilling machine. All service or repair should be done by an authorized Nitto dealer.

Secure Your Work

- Always secure your work piece. Improperly mounted

work can become loose. This can cause severe injuries. Always secure all work.

- Always use a vice or a clamp. Do not attempt to hold any work piece with your hand. Attempting to hold a work piece with your hand may cause severe injuries. Always use a vice or clamp to hold the work piece.
- Always secure your drilling machine. Improperly mounted drilling machine can come loose. This can cause severe injuries. Always secure the drilling machine.

Avoid Clutter

- Always stay clear of other objects. Cluttered work areas cause accidents. Always keep a clean work area and stay away from other objects.

Always Remove Spanner Wrenches and Adjustment Tools

- Always remove spanner wrenches and adjustment tools after adjustments have been made to the drilling machine. Always remove all adjustment tools before using the drilling machine.

Always Use a Cutter that is Appropriate for Your Work

- Always use a cutter that is appropriate for your work. Avoid heavy-duty work that is beyond the capacity of your drilling machine. If the work exceeds the capacity of your drilling machine, this can cause accidents and severe injuries. Always use the drilling machine in accordance with its performance specifications.

SAFE HANDLING

- Never leave the magnetic drilling machine unattended while it is running. When the machine is unattended, disconnect the power source. Do not leave the work area until the machine comes to a complete stop. Operating the machine while it is unattended can cause accidents that may result in severe injuries.

HOW TO STORE YOUR MAGNETIC DRILLING MACHINE

- Always store the machine in a dry area.
- Always keep the machine out of the reach of children.

HOW TO CARRY YOUR MAGNETIC DRILLING MACHINE

- Disconnect the power and turn off the machine whenever you carry the machine.

MAINTENANCE

Do not take apart or modify your magnetic drilling machine.

- Do not attempt to disassemble or modify your

magnetic drilling machine.

- Do not modify your magnetic drilling machine. Modifications can cause accident and severe injuries.
- All service and repairs must be performed by an authorized Nitto dealer. Any attempt to service or repair the machine yourself may result in an accident and severe injuries.

Check all Parts for Damage.

- Always inspect the magnetic drilling machine before use.
- Always check that the pilot pin and cutter are in good condition. Use of the machine with worn pilot pins or worn cutter can cause accidents and severe injuries.
- Inspect all cutter before you put them on the magnetic drilling machine.
- Do not operate the magnetic drilling machine with a damaged or worn cutter. Do not operate the machine with a damaged or worn pilot pin. Do not operate the machine with any damaged accessory. Operating the machine with any damaged part or accessory can cause accidents and severe injuries. If there is any damage to the magnetic drilling machine do not operate the machine. Take it to an authorized Nitto Dealer for repair.
- Always have the magnetic drilling machine repaired at an authorized Nitto dealer. Always take the magnetic drilling machine to an authorized Nitto dealer for service, repair and replacement parts. If you cannot locate an authorized Nitto dealer near you, please contact your sales representative.
- Always use Nitto genuine parts. The use of improper or non-Nitto parts can cause accidents and severe injuries. Never use unauthorized parts. To obtain genuine Nitto parts, contact your sales agent.
- Do not remove any nameplate from your magnetic drilling machine. Do not remove any labels from your magnetic drilling machine. If any label or nameplate is damaged contact your sales agent for a replacement.

POWER TOOL SAFETY

WARNING

- Always make sure that the machine is properly grounded. If the machine is not properly grounded, someone can get an electric shock.
- If you have any doubt about the grounding of the magnetic drilling machine, contact a licensed electrician.
- Never connect the grounding conductor to a gas

pipe. This will result in an explosion and severe injuries or death.

- Always check the grounding conductor. If you have any doubts about the grounding conductor contact a licensed electrician.
- Wiring connections to a grounding rod require the expertise of a licensed electrician. Do not attempt the wire connections yourself. Always contact a licensed electrician.
- Do not abuse the power cord. A damaged power cord can cause an electrocution. A damaged power cord can cause fires. Always inspect the cord. If the cord is damaged, do not use the magnetic drilling machine.
- Do not carry the machine by the cord. Do not pull the cord to disconnect it from a socket.
- The cord can become damaged from heat, contact with sharp objects or from being twisted. Always inspect the cord. Do not use the machine if the cord is damaged.
- Always use a ground fault circuit interrupter. The use of a ground fault circuit interrupter may be required by government regulations. The failure to use a ground fault circuit interrupter may result in electric shock.
- Avoid starting the magnetic drilling machine abruptly or unintentionally.
- Always make sure that the switch is turned off before connecting the power source.
- Always disconnect the power source and turn off the switch before setting up for work operations. Always disconnect the power and turn off the switch when inspecting work. Always disconnect the power and turn off the switch before attempting any maintenance. Failure to disconnect the power and turn off the switch during set up, inspection or maintenance can cause accidents and severe injuries.

ABOUT YOUR NITTO PORTABLE MAGNETIC DRILLING MACHINE

DANGER

Do not use your portable drilling machine on the ceiling.

- Use of the portable drilling machine on the ceiling is dangerous. The machine could fall. The falling machine could cause severe injuries or death. (Fig.1)

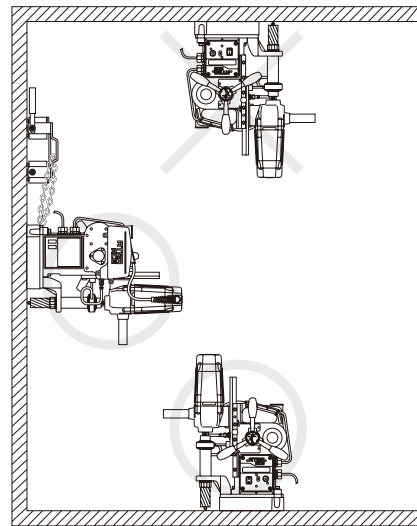

Fig. 1

WARNING

Do not use the Magnet for more than five hours.

- More than five hours of uninterrupted operation may cause a fire. Five hours of uninterrupted operation generates extreme heat in the Magnet. This heat can cause a fire. Do not touch the Magnet. When the Magnet is hot, touching it will cause a severe burn injury. Never use the Magnet for more than five continuous hours. When you are not using the Magnet, turn the switch to the "OFF" position and pull the plug out of the power source.

Do not use the Drill Motor for over 30 minutes.

- Uninterrupted operation of the Drill Motor for over 30 minutes generates heat. This heat can cause a fire. Never use the Drill Motor for over 30 minutes. When you are not using the Drill Motor, turn the switch to the "OFF" position and pull the plug from the power source.

Use only on magnetic materials.

- Your portable drilling machine cannot be used on non-magnetic materials, such as aluminum, stainless steel, copper or alloys. The Magnet will not work on non-magnetic materials. Attempting to use the Magnet on non-magnetic materials could cause an accident.

Use caution during wall operation.

- When using your portable magnetic drilling machine on a magnetic wall, always use caution.
- Never stand under the machine.
 - * Never allow anyone to stand under the machine.
 - * Never put any part of your body under the machine.
 - * If the machine falls, it could result in severe injury or death.
- Always remove cutting oil from the tank before using the machine on a wall. You must manually apply cutting oil to the cutting tool.

Always use a work piece that is at least 3/8" (9 mm) thick.

- The work piece must be at least 3/8" (9 mm) thick. If a work piece is too thin, the magnetic power of your machine will decrease. This will cause the machine to move during operation. This could result in an accident. (Fig.3)

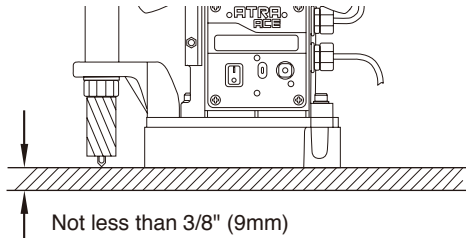

Fig. 3

Use an iron back-up plate.

- If the work piece is less than 3/8" (9 mm) thick, you must use an iron back-up plate that is more than 13/32" (10 mm) in thickness. The surface area of the iron back-up plate must be greater than the surface area of the Magnet. An appropriate back-up plate is necessary to boost the holding power of the Magnet. (Fig.3)

Use of an inappropriate back-up plate can result in an accident, If the back-up plate is not thick enough or big enough, the machine will come loose during operation. This can result in an accident and severe injuries.

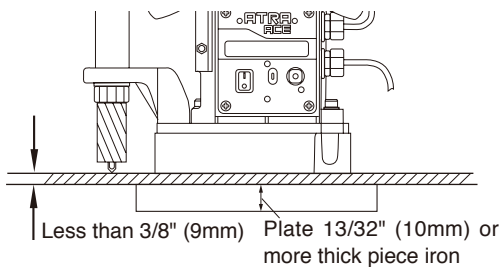

Fig. 3

Always keep surfaces clean.

- Always keep the Magnet surface clean. Always keep the work piece surface clean. If there are any foreign objects between the Magnet and the work piece surfaces, this will reduce magnetic power. This could cause the machine to move during operation. This can result in an accident. Keep all surfaces clean of rust, chips or other foreign material.

Do not place the machine over a hole.

- Do not attempt to position the Magnet over a hole. Attempting to straddle a hole will reduce the power of the Magnet. This will cause the work piece to

come loose during operation and can cause an accident.

Always use a Chain to secure the machine.

- If the machine falls, it can cause severe injuries. There is always a possibility that magnetic power can be lost or reduced because of a power failure. Magnetic power can be lost on rough surfaces. You must take precautions to prevent the machine from falling.
- This machine comes with the Chain. The Chain is to be used to fasten the machine to the work piece. If you do not use the Chain, it is possible that the machine may fall. (Fig.4)
- If use of the Chain is not possible because of the size of the work piece, you must use another method of securing the machine. Use a Supporting Magnet Ass'y to prevent the machine from falling.
- The use of a Supporting Magnet Ass'y is shown below. (Fig.5)

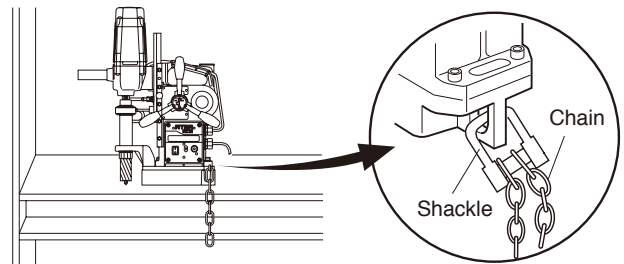

Fig. 4

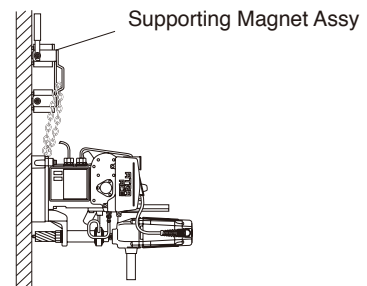

Fig. 5

Always set the Magnet in the proper position.

- Always set the Magnet parallel to the longitudinal direction of the material. Failure to set the Magnet in the proper position may result in reduced magnetic power. This can cause the machine to move in operation. This can cause an accident resulting in severe injuries.
- When using on H-section steel, as shown in the figure below, set the Magnet in a direction parallel to the longitudinal direction of the material. This will ensure that the Magnet is in the best position for magnetic attraction.(Fig.6)
- Poor magnetic power may result in damage to the cutter or damage to the work piece.

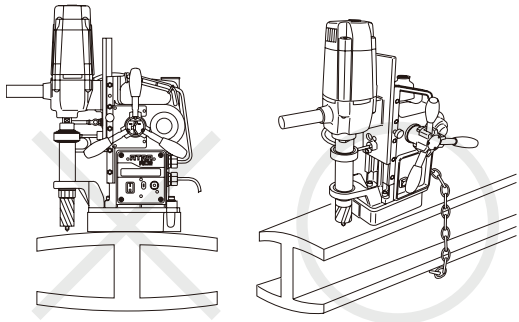

Fig. 6

Be careful about chips.

- Keep your hands away from the cutting area at all times. During drilling, there will be chips. The chips are sharp. The chips are rotating with the cutter. Any contact with the chips can cause severe injuries.

Do not touch the slug.

- Do not touch the slug. The slug is very hot. It will cause severe burns. Make sure that no one touches the slug. Make sure that there is no one below the work area during operation. Hot slugs will fall. Hot slugs can cause severe burns, other severe injuries, or even death. Always wear protective equipment, including protective headgear, eye protection, hearing protection, and gloves. Do not allow any person without protective equipment to come near the machine.

Do not use your hands to remove chips.

- Chips have sharp edges. Use a screwdriver to remove chips. If you use your hands to remove chips, you can be injured, even if you are wearing gloves. Do not use your hands to remove chips under any circumstances.

The cutting edge is sharp.

- The cutting edge is sharp. If you do not wear gloves, you will be cut. Attempting to change the cutter can result in severe injuries.

Do not use Cutting Oil for other purposes.

- Cutting Oil should be used only for drilling. Please refer to Section 5-5 of this manual for further warnings and instructions about Cutting Oil.

The Drill Motor will stop automatically when drilling operation is completed. If the Drill Motor fails to stop automatically, turn off the Motor Switch to stop it and then contact sales agent from which you have purchased your machine or an authorized dealer near you for repair.

⚠ CAUTION

Do not use power that is generated by an engine-driven welder.

- The use of an engine-driven welder as a power source may cause your magnetic driven machine to

malfunction, Power from an engine-driven welder can damage the electronic circuits in your portable drilling machine.

Use a Proper extension cord.

- Do not use an extension cord that is too thin. Do not use an extension cord that is too long. Do not use an extension cord that is wound on a drum. Do not share an extension cord with other motor-driven tools. These uses can cause voltage to drop and can reduce the holding power of the magnet, causing the machine to move during operation. This can decrease performance and may cause damage to the machine. (Fig.7)

Extension Cord	
Max length	Size (nominal cross-section area of the conductor)
10 m (32.8ft)	Min 1.25 mm ² (AWG16)
20 m (65.6ft)	Min 2 mm ² (AWG14)
30 m (98.4ft)	Min 3.5 mm ² (AWG12)

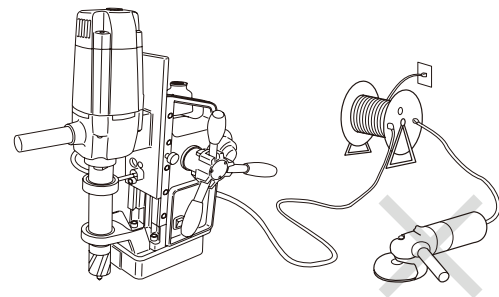

Fig. 7

Do not use this machine on the steel material being electrically welded.

- When the electric welder is not properly grounded, electricity will run through the Atra Ace machine via its Magnet, causing possible failure or malfunctioning, which in turn may cause accident.

Do not force to feed cutter when drilling manually.

- Because the Hi-Broach and Jet-Broach have rather thin cutting edges with less cutting pressure resistance as compared to twist drill, do not force to feed the cutter when drilling manually. If you feed it with too much force, the cutter may break or end up with shorter life than otherwise.

Always use a compatible Pilot Pin.

- The Pilot Pin must be compatible with the cutter. An improper Pilot Pin may result in an accident. See Section 5-3 to identify compatible Pilot Pins and cutters. The proper Pilot Pin to be used will vary, depending on the type of cutter, the diameter of the cutter, and the length of the cutter.

Do not switch to auto while drilling in manual mode.

- When you want automatic drilling, set the machine

to auto mode first and then start drilling.

Do not switch over to auto mode in the middle of manual drilling operation: the Drill Motor may come to a stop if you do so.

Do not apply manual force when feeding in auto mode.

- Do not apply force to the Rod Handle when feeding in auto mode (with the Rod Handle pushed toward the machine).

Do not start drilling with manual feed.

- Do not start drilling with manual feed. Once you have started with manual feed, however, you must not change mode to automatic feed half way through the operation because the Drill Motor may come to a stop making it impossible to complete the hole.

Leaving the machine alone in a subzero C° environment for many hours may cause Drill Motor start-up failure at the initial startup. This is nothing unusual. Set the auto-feed switch to OFF (with the Rod Handle pulled out toward the operator) and run the machine idly for a few minutes. That should take care of initial startup failure.

1. APPLICATION

This is a portable drilling machine with a Magnet, geared to drilling mild steel (or equivalent) using One-Touch type Jet-Broach or Hi-Broach. The machine will be mounted on the workpiece to be drilled with the Magnet securely fastening the machine to the workpiece while drilling takes place.

2. RECEIVING INSPECTION

Upon unpacking, check to see that the shipment is complete without damage or oil leakage in transport. Should you find any damage or short-shipment, please contact sales agent through which you have purchased your machine or an authorized dealer near you for corrective actions.

Package Contents	Q' ty	Check
ATRA ACE	1set	
Pilot Pin 08035	1	
Hex. Socket Screw Key 3	1	
Spanner 8X10	1	
Cutting Oil 0.5ℓ Can	1	
Side Handle	1	
Chain	1	
Guard	1	
Instruction Manual	1	

3. PART NAME

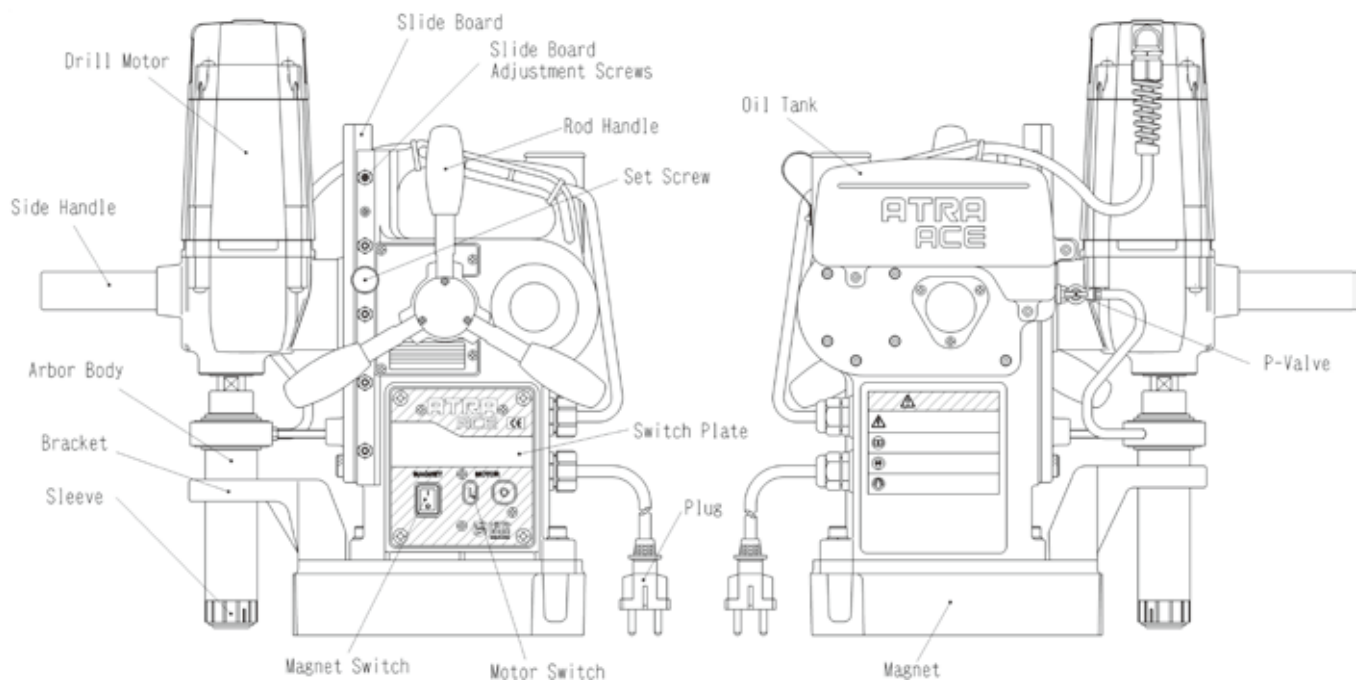

Fig. 8

4. FUNCTIONS OF ELECTRONIC CONTROL

4-1. Overload Detecting Function

When overload occurs during drilling operation, the overload detector puts the following functions to work. Please note, however, that there may be cases where the overload detector does not work properly if power is drawn from an engine generator with fluctuating output voltage, sometime tool high and sometime too low.

● Automatic Feed Rate Control Function

Automatic drill feed starts slowly for the first few seconds and then it picks up speed automatically to an appropriate level in terms of cutting load applied to the cutter. In addition, a cutter diameter factor is also taken into account for automatic feed rate control.

● Automatic Stop Function

Overload to the Drill Motor or feed motor automatically stops the drill and ongoing feed, preventing possible damage to the machine and cutter. However, if a worn or blunt cutter is being used, it may break.

4-2. Automatic Cycle Stop Function

When drilling operation is complete with the machine relieved of cutting load, the Drill Motor stops automatically.

4-3. Limit Switch Function

Even if the automatic cycle stop function fails to operate and the drill continues to feed down, the Limit Switch will stop the down-feed near the lower limit of the stroke and the Drill Motor.

4-4. Lateral-Shifting Detection Function

This function stops drill feed and the Drill Motor when lateral shifting of the Magnet is detected.

4-5. Re-Start Prevention Function

The re-start prevention function comes into play when power failure is restored that has occurred during operation.

Thanks to this feature, when a plug that has been disconnected during operation is re-plugged into the receptacle or when power failure is restored that has occurred during operation, the Drill Motor will NOT restart automatically preventing possible accident -- although Magnet lamp will come on and magnetic power restored.

To resume operation, turn ON the Motor Switch on the side of the machine to start the Drill Motor.

4-6. Magnet Interlocking Function

When the Magnet fails the Drill Motor will not start revolving. To repair defective Magnet, please contact sales agent through which you have purchased your machine or an authorized dealer near you.

5. MACHINE SETUP

⚠ WARNING

- When setting up machine, turn off the Magnet Switch and disconnect the power supply plug from power source.

5-1. Mounting Parts

Mount the Side Handle on the Drill Motor.

5-2. Using Cutter

⚠ CAUTION

- Use One-Touch type cutters only.
- For better workability and safety, do not use worn or damaged cutters.

5-3. Combination of Cutter and Pilot Pin

CAUTION

- Do not use any other combinations than those shown in the compatibility table.

Use a Pilot Pin appropriate for the cutter. (Fig.9)
A Pilot Pin to be used varies depending on the cutter type, diameter, length (depth). A wrong combination of cutter and Pilot Pin would not allow slug to be ejected at the end of drilling and/or prevent Cutting Oil from reaching the cutting point, resulting in cutting tool damage.

PILOT PIN	HI-BROACH Cutters
06025 PN:TK01167 6.35 dia. 81 mm 5 dia.	HBO 14 - 17 dia. Depth 25 mm
08025 PN:TJ12696 76 mm 8 dia.	HBO 17.5 - 35 dia. Depth 25 mm
06050 PN:TK01166 6.35 dia. 112 mm 5 dia.	HBO 14 - 18 dia. Depth 50 mm
0850 PN:TK00802 8 dia. 100 mm 7 dia.	HBO 19 - 35 dia. Depth 50 mm
08050 PN:TJ16019 112 mm 8 dia.	
PILOT PIN	JETBROACH Cutters
08035 PN:TJ15859 91 mm 8 dia.	JBO 17.5 - 35 dia. Depth 35 mm
08050 PN:TJ16019 112 mm 8 dia.	JBO 17.5 - 35 dia. Depth 50 mm
08075 PN:TJ17436 133 mm 8 dia.	JBO 17.5 - 35 dia. Depth 75 mm

Fig. 9

5-4. Mounting/Removing Cutter

WARNING

- Do not use any other combinations of Pilot Pin and cutter than those shown in the compatibility table.
- Wear safety gloves when replacing cutter.

(1) Bring the Drill Motor up by turning the Rod Handle clockwise. (Fig. 10)

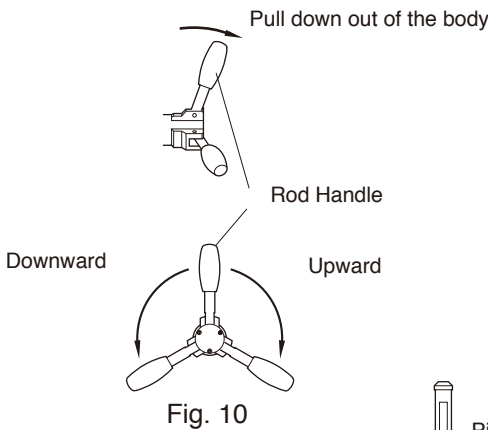

(2) Insert a Pilot Pin, appropriate for the cutter size, into the cutter. (Fig.11)

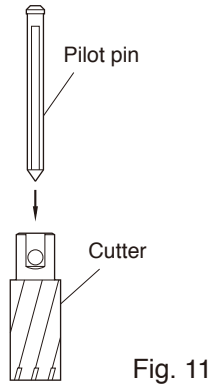

(3) Align the depression in the cutter with the white line on the Sleeve, and then insert the cutter. When you insert the cutter far enough the Sleeve will turn clockwise and lock with a clicking sound..

* When you find it hard to insert the cutter, turn the Sleeve counterclockwise and do over. (Fig.12)

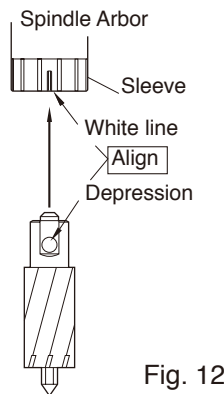

(4) To remove the cutter, turn the Sleeve counterclockwise. The cutter will come off. (Fig.13)

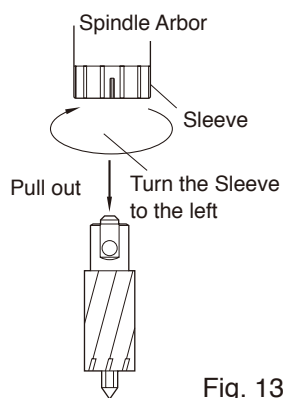

5-5. Preparation of Cutting Oil

Cutting Oil Safety Precautions

WARNING

(1) Use

- Use Cutting Oil for cutting purpose only. Do not use it for household purposes

(2) Handling Precautions

- The Cutting Oil contains amine. Do not mix it up with rust inhibitor, etc. containing nitrite.
- Wear safety glasses for eye protection when handling Cutting Oil: eye injury may results if it gets into your eyes.
- Wear protective gloves for hand protection when handling Cutting Oil: skin injury may result if it comes into contact with your skin.
- Wear respirator when exposure to respiratory hazards with oil mist or vapor is anticipated. Inhalation of oil mist or vapor may make you feel sick.
- When diluting Cutting Oil, follow the instructions per the Operation Manual.
- Keep Cutting Oil out of reach of children.
- Do not drink Cutting Oil.

(3) First Aid

- If Cutting Oil gets into your eyes, immediately open your eyelids with your fingers and wash your eyes with plenty of water for at least 15 minutes. If your eyes feel irritated, consult with a medical doctor and follow his/her instructions.
- If Cutting Oil comes into contact with your skin, immediately wash it away with plenty of water and soap. Take off contaminated clothes. Clean the clothes if you need to wear it again. If your skin feels irritated, consult with a medical doctor for medical instructions.
- If someone inhales oil mist or vapor, immediately take him/her to an area where fresh air is abundant and wrap up his/her body with a blanket, etc. to keep body temperature. Have him/her take a rest and consult with a medical doctor for medical instructions.
- If someone drinks Cutting Oil, immediately make him/her drink plenty of water and vomit it. Consult with a medical doctor for medical instructions. When unconscious, do not pour water into his/her mouth nor induce him/her to vomit.

(4) Instructions in Case of Fire

- If fire breaks out in the vicinity, wear PPE (personal protective equipment) and use foam, powder or CO² fire extinguisher to put the fire out from the windward.

(5) Storage

- When storing Cutting Oil after use, put it into a container and put a lid on for tight sealing so that dust or moisture, which is a catalyst for contamination, may not get in.
- Avoid direct sunlight, rainwater or the like and store Cutting Oil in a dim cool area.

(6) Disposal

- For disposal of concentrate solution and used fluid, request a waste-disposal company to dispose them as industrial waste in accordance with the local laws and regulations.
- Treat flushing water through pH adjustment, condensation/sedimentation, activated sludge process, activated carbon adsorption, etc., and discharge it in accordance with the regulations of your local municipal bylaw.
- Residual dross will remain in an emptied container: be careful when handling an empty container.

(7) Others

- When Cutting Oil is poured into another container for use, post chemical and label information at the site where it is kept. At the same time, keep the Operation Manual handy so that it can be referred to whenever necessary.
- For further details, contact us for product safety data sheet.
- All the information and descriptions that have been provided are based on the currently available documents and information, which may be revised upon our new recognition and/or discovery.
- The precautions provided apply to regular handling. If special handling method is used, take safety measures that are suitable for your applications and usage.
- The information contained herein is for your reference purpose only, to which we make no warranty of any kind and for which we shall not be held responsible.

Preparation of Cutting Oil

- (1-1) Use our genuine-product Cutting Oil (blue). If other Cutting Oil is used, the cutting performance and service life of cutter would be decreased.
- (1-2) Use tap water to dilute Cutting Oil by 8- to 10-fold. Do not use well water.
- (1-3) The oil tank is of the stationary type. Remove the rubber cap and pour Cutting Oil from the Oil Tank inlet. Do not spill Cutting Oil on the machine.

5-6. Connecting the Power Supply Plug to Power Source

- Before connecting the power supply plug to power source, turn off the switch.
Always use the correct voltage for power source.

6. MACHINE OPERATION

WARNING

- Always Wear Safety Glasses.
- Always Wear Hearing Protection.
- Wear respiratory protective equipment.
- Never touch the mounted cutter and the rotating parts of the machine such as the Spindle Arbor after the power cable is connected to power source.

CAUTION

- Do not use hard material such as a screwdriver, to operate the Motor Switch. This may damage the panel and switch, which would lead to machine failure.

6-1 Start and Stop

(1) Magnet On

Set the Magnet Switch to On the Magnet will activate.

(Fig. 14)

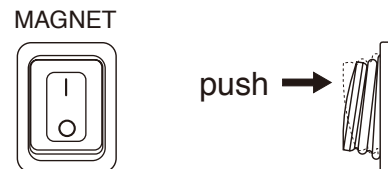

Fig. 14

(2) Drill Motor On

Set the Motor Switch to On . The Drill Motor will start.(Fig. 15)

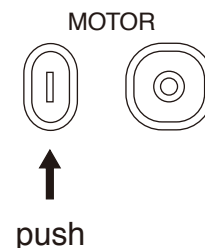

Fig. 15

(3) All Stop

When the Motor Switch is set to off, the Motor will stop. When the Magnet Switch is set to the Off position, the magnet will be deactivated and all functions will stop.

6-2. Drilling Procedure

(1) Punch Marking

Put a rather large punch mark in the workpiece by driving a punch down with a hammer. The punch mark will be used as a guide for drilling operation that follows, so it must be made in accurate position. (Fig.16)

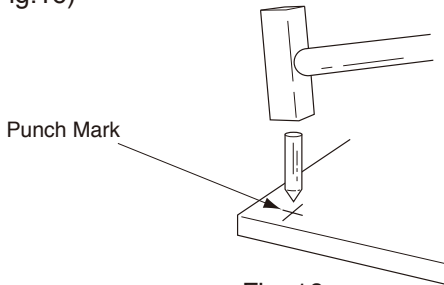

Fig. 16

(2) Keep the Magnet and Workpiece Contacting Surfaces Clean.

⚠ WARNING

- Always keep surfaces clean.

Always keep the Magnet surface clean. Always keep the work piece surface clean. If there are any foreign objects between the Magnet and the work piece surfaces, this will reduce magnetic power. This could cause the machine to move during operation. This can result in an accident. Keep all surfaces clean of rust, chips or other foreign material.

(3) Aligning with Punch Mark.

Turn the Rod Handle counterclockwise to slightly lower the cutter and align the tip of Pilot Pin to the punch mark. (Fig.17)

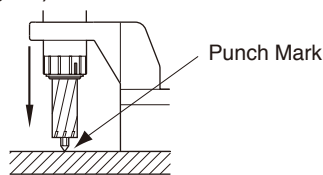

Fig. 17

(4) Magnet ON

⚠ CAUTION

Make sure the magnet is clinging to the workpiece.

Set the Magnet Switch to On and the magnet will be activated. (Fig. 18)

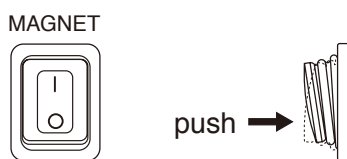

(Fig. 18)

⚠ WARNING

- Check to see that Magnetic power is at work.

Turn on the Magnet Switch. The switch lamp will glow and magnetic power will come on.

(5) Controlling Cutting Oil Flow.

Open the P-Valve and turn the Rod Handle. The Pilot Pin will move up allowing Cutting Oil to flow.

(6) Mounting the Guard

Mounting the Guard as shown. (Fig.19)

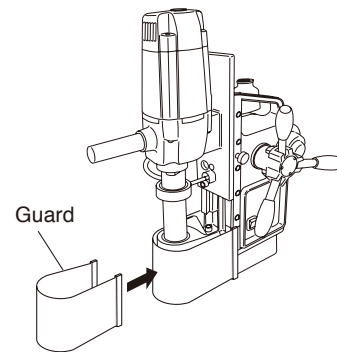

Fig. 19

(7) Drill Motor ON

⚠ CAUTION

Do not touch the rotating parts.

Set the Motor Switch to On . The Drill Motor will start. (Fig. 20)

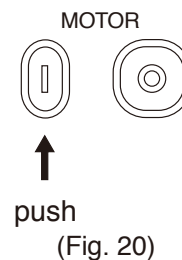

(Fig. 20)

⚠ WARNING

- Do not touch revolving parts.

Press the Drill Motor ON Switch to start the Drill Motor

(8) Drilling

Automatic Feed

⚠ CAUTION

- Once drilling feed has started, do not touch the Rod Handle until drilling cycle is complete.

To start automatic feed, push the Rod Handle toward the machine. As the cutter will be fed at low speed at the start you do not have to use manual feed. (Fig.21)

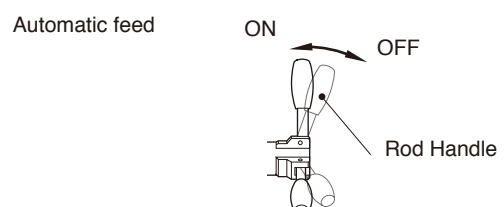

Fig. 21

CAUTION

- Do not use automatic feed when the workpiece has a tapered bottom surface through which a hole is to be drilled.

When putting a hole through workpiece with a tapered bottom surface or bottom surface with a radius, such as angle, channel, H-section steel, etc., use low feed rate at the start as well as toward the end of drilling operation where the likelihood of tool chipping is high. (Fig.22)

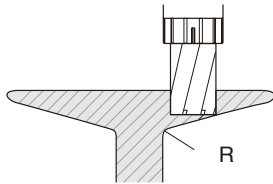

Fig. 22

(9) Finishing Drilling Operation

WARNING

- When drilling cycle is complete, the Drill Motor will stop automatically. If it does not, it is a machine failure. Turn off the Motor Switch and contact sales agent through which you have purchase your machine or an authorized dealer near you for repair.
- Be alert at the end of drilling operation when slug will automatically pop out. Do not touch slug: it is very hot and has sharp edges.

When drilling cycle is complete, the Drill Motor will come to a complete stop automatically. Once it has come to a stop, pull the Rod Handle outward away from the machine and turn off the automatic feed switch. Turn the Rod Handle clockwise to raise the Drill Motor. Then promptly turn off the Magnet Switch. If a Magnet is left alone with its switch turned on for many hours, electric current will keep flowing through the Magnet at the cost of shortened service life.

(10) Removing Slug

Do not proceed to the next operation without removing the slug from the operation just finished. At the end of drilling operation slug will pop out automatically ejected by the spring-operated Pilot Pin. Should a slug left in the hold sticking, remove it from the hole by tapping the collar of the slug with a needle stick or something. (Fig.23)

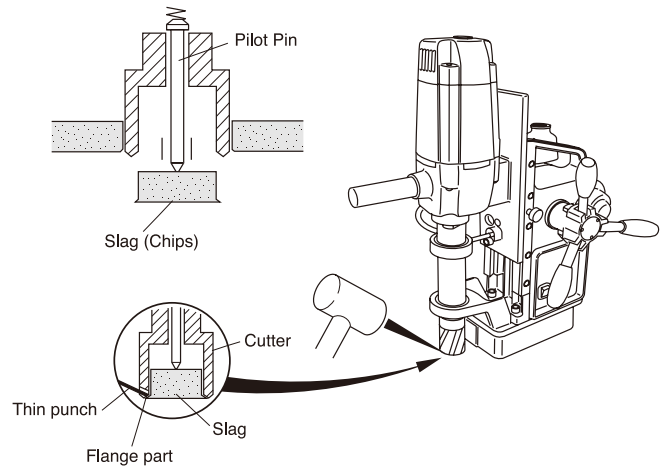

Fig. 23

6-3. Drilling Oblong Hole

CAUTION

- Always drill oblong hole manually and slowly.

Drill oblong hole in the order of ①, ②, ③. For the steps ② and ③, use manual feed and take care so that the cutter may not be fed into the workpiece with too much force. If automatic feed is used, damage to the cutter or unexpected accident may result. Use a file to take off any sock that is left unmachined. Spacing between each step of drilling operations should be so arranged that the Pilot Pin will always hit the sold material yet to be machined. (Fig.24)

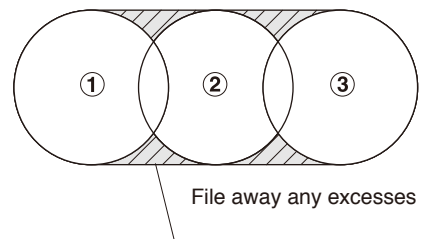

Fig. 24

6-4. Drilling Stacked Plates

CAUTION

- Remove slug as each plated is finished: otherwise, being blocked by the slug left unremoved, the cutter cannot cut into the next layer of plate, which results in the Magnet base being pushed up possibly causing accident.
- For stacked plates drilling, always use manual feed and drill slowly and carefully.
- Before drilling stacked plates, securely clamp the plates together in place.
- When drilling stacked plates, retract the cutter as each layer of plate is finished in order to remove slug from the drilling area, then put another hole in the next layer of plate.

7. TROUBLESHOOTING

WARNING

- Never attempt to repair machine yourself: injury or damage to equipment may result.
- Please feel free to consult the sales agent through which you have purchase your machine or an authorized dealer, when the following symptoms appear or when you have any questions about our products.

This machine is electronically controlled. It will stop when it picks up noise from power source or when malfunction occurs to the electronic control. When you notice the following symptoms, pull the Rod Handle outward away from the machine to turn OFF automatic feed and raise the Drill Motor to ensure safety and conduct inspection.

Problem	Causes	Solutions
Switch lamp does not come on when Magnet Switch is turned on.	Power supply plug is not connected to socket.	Connect power supply plug to socket.
Drill Motor does not start when Motor Switch is turned on.	Magnet is disconnected.	Request for repair.
	Limit switch is activated near the lower limit of drill stroke.	Slightly raise Drill Motor and release limit switch.
Drill Motor stops during drilling. (Magnet is not working with Magnet lamp not illuminating.)	Power failure has occurred or power supply plug is disconnected.	After power failure is restored or power supply plug is re-connected, turn on Motor Switch again.
Drill Motor stops completely in the middle of drilling operation.	No Cutting Oil or insufficient Cutting Oil	Increase flow rate of Cutting Oil.
	Cutting edges jammed and stuck with cutting chips.	Remove.
	Worn cutting edge.	Regrind or replace with new one.
	Using cutter of other make	Use Nitto brand cutter.
	Using Cutting Oil of other made.	Use Nitto brand Cutting Oil.
	Switching over to auto feed in the middle of operation that started with manual feed.	Use the automatic feed from the beginning.
	Temporal glitch with electronic control.	Restart .
	Overload protection triggered	Restart .
Lateral shifting of Magnet is detected by lateral position sensor, bringing machine to a complete stop.	Workpiece too thin.	Use back-up plate: thickness 13/32" (10 mm) or more.
	Chips under Magnet base.	Clean it up.
	Worn cutting edge.	Regrind or replace with new one.
	Effective Magnetic force too weak.	Ask for repair.
Drill Motor does not come to a stop when drilling operation is complete.	Near-exit restarting	Normal. Motor Switch OFF
	Almost no cutting pressure throughout drilling operation (workpiece too thin.)	Normal. Motor Switch OFF
	No lubrication to Arbor Body or needle bearing.	Lubricate.
Drill Motor stops within several seconds after Motor Switch is turned on.	Frozen machine	Turn on and off the switch several times to warm up machine.

8. MAINTENANCE/SERVICE

WARNING

- Always disconnect the power and turn off the switch before attempting any maintenance. Failure to disconnect the power and turn off the switch during set up, inspection or maintenance can cause accidents and severe injuries.
- Check to see periodically that mounting screws are tight. If you find them loose, retighten.

8-1. Tighten Set Screw When Machine is Not Used

For the purpose of safety, when you do not use the machine temporarily or on a long-term basis, raise the Drill Motor and set it in position with the Set Screw so that it will not come down on its own weight. If you leave the machine alone with the Drill Motor in a lowered position, the Pilot Pin and/or cutter may be damaged when the machine is relocated. (Fig.25)

8-2. Grease the Sliding Surfaces from Time to Time

Grease the machine body and Slide Board from time to time. (Fig.25)

8-3. Slide Board Clearance Adjustment

Excessive clearance between the machine body and Slide Board would deteriorate not only drilling performance but also cutting tool life to a substantial degree. If you find excessive clearance, make adjustment by tightening 5 slide board adjusting screws on the side of the machine using the same torque all round so that the Drill Motor will not come down on its own weight. (Fig.25)

8-4. Bracket Inspection and Oiling

Among other things, drilling accuracy hinges on the Bracket that supports the Arbor Body. See that the (three Hexagon Socket) Bracket mounting bolts are tight, from time to time. (Fig.25)

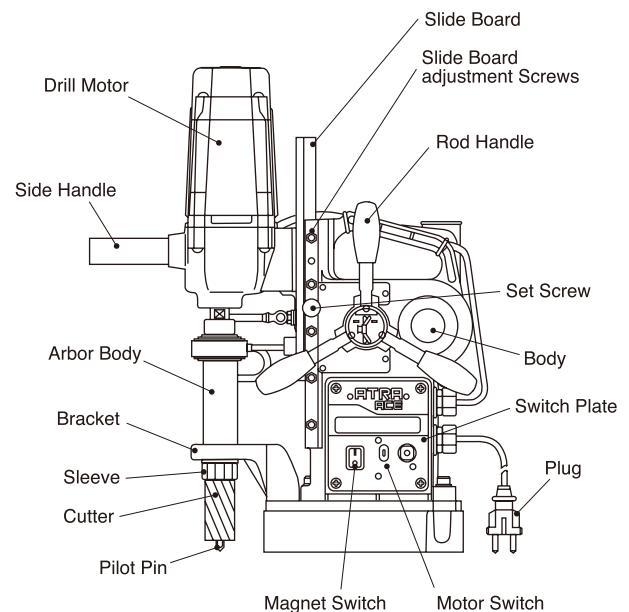

Fig. 25

8-5. Keep the Tip of Pilot Pin Sharp

When the tip of Pilot Pin gets dull, it sometimes fails to seat into punched hole, causing drilling accuracy to deteriorate. See that the tip is sharp from time to time.

If you find it too dull, regrind or replace as required. When regrinding do so carefully, for grinding with too much force may cause the tip to get dull or soften the material to such a degree that it is no longer usable. (Fig.26)

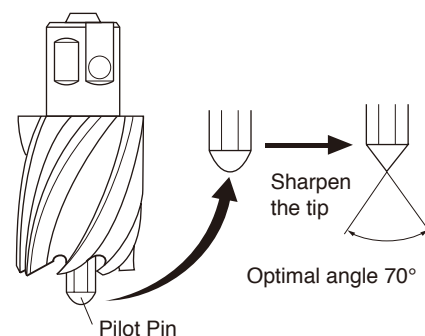

Fig. 26

8-6. Recovery Measures When Pilot Pin Gets Jammed

When you change cutting tool you also change Pilot Pin, which acts as a guide for the cutting tool. However there are times when the pin does not come off easy with cutting chips in the clearance between the cutting tool and pin, causing jamming. In such case, tap the tip of Pilot Pin with a wooden hammer, etc., and pull it off. (Fig.27)

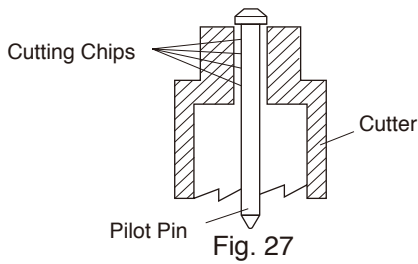

Fig. 27

8-7. Cutter Regrinding

When you need to regrind cutter, please contact sales agent through which you have purchased your machine or an authorized dealer near you.

8-8. Carbon Brushes Inspection and Replacement

Check Carbon Brushes for wear periodically.

When the length of Carbon Brushes gets as short as 5/16" (8 mm), replace it with a new one, for, if you do not, chances are that you will have a rectification problem which may cause machine failure. (Fig.28)

- (1) Loosen the tap screws to remove the cap.
- (2) Take out the Carbon Brush and replace it with a new one.
- (3) Put the cover on and securely tighten the tap screws. When tightening the tap screws, see that the tap screws are screwed in along the existing screw threads – without cutting new threads.
- (4) After replacement, run the machine with no load for approx. 10 minutes.

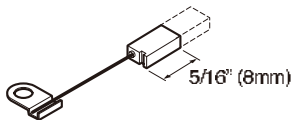

Fig. 28

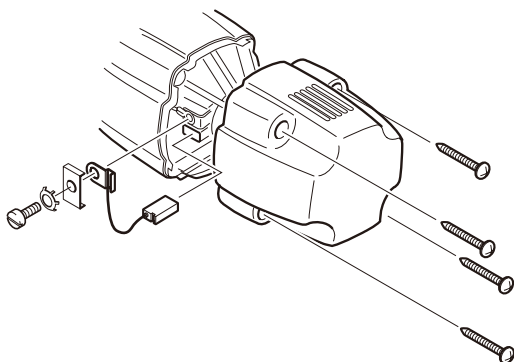

Fig. 29

9. OPTIONAL PARTS

9-1. Nitto-Brand Cutting Oil



Use Nitto-brand Cutting Oil for Atra Ace.

Part No.	Part Name
TB01507	Cutting Oil 2 ℓ (Light Blue)

9-2. Pilot Pin

(metric sizes)

Part No.	Part Name	Depth(mm)	Applicable cutter (mm)
TK01167	Pilot Pin 06025	25	Hi-broach 14 - 17 dia.
TJ12696	Pilot Pin 08025		Hi-broach 17.5 - 35 dia.
TJ15859	Pilot Pin 08035	35	Jetbroach 17.5 - 35 dia.
TK01166	Pilot Pin 06050	50	Hi-broach 14 - 18 dia.
TJ16019	Pilot Pin 08050		Hi-broach 19 - 35 dia.
(TK00802)	Pilot Pin 0850		Jetbroach 17.5 - 35 dia.

※ ():Special Order

9-3. Supporting Magnet Ass'y

Part No.	Part Name
TB04374	Supporting Magnet Ass'y

9-4. Sleeve 6.5 Ass'y for Twist Drills (Fig.30)

Part No.	Part Name
TB02536	Sleeve 6.5 Ass'y

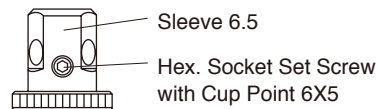

Fig. 30

9-5. Chip Breaker

When chips are not smoothly discharged during drilling, the overload detection will be frequently triggered to stop the Drill Motor, particularly when plate thickness is 1-3/8" (25 mm) or thicker. In such case, an optional Chip Breaker may be used to ease chip congestion.

9-5-1. Mounting Chip Breaker

CAUTION

- When setting Chip Breaker, see that the tip of blade may not come into contact with cutting tool.

Chip Breaker breaks cutting chips formed in drilling into small pieces and facilitates chip discharging.

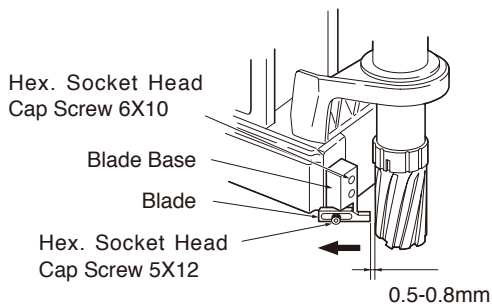

Fig. 31

(1) Mount Blade Base. (Fig.31)

- Use two Hex. Socket head Cap Screws 6 X 10 to mount the Blade Base on the front face of Magnet.

Here, see that the bottom face of the Blade Base is flush with the bottom face of Magnet. When the bottom face of the Blade Base sticks out from the bottom face of the Magnet, the magnetic force it sends out can not be made fully use of for secure fastening.

- Use the Hex. Socket head Cap Screws 5 X 12 to mount a blade to the Blade Base in the direction as shown in the figure.

(2) Mount cutter.

Loosen the Hex. Socket head Cap Screws 5 X 12 and pull the Blade in the direction as shown by the arrow until it no longer moves. And then, mount a cutter.

(3) Set the blade.

Set the Blade in the way that the cutter and the blade will have a clearance of 0.5 mm - 0.8mm and fasten it securely to the Blade Base with Hex. Socket head Cap Screws 5 X 12.

9-5-2. Chip Breaker Ass'y

Part No.	Part Name
TB05186	Chip Breaker Ass'y
(TQ04949)	Blade
(TQ04950)	Blade Base
(TP14178)	Hex. Socket Head Cap Screw 6 X 10
(TP01945)	Hex. Socket Head Cap Screw 5 X 12

The part number with () are include in the Ass'y parts written above them.

9-6 Ordering parts

Hi-Broach One-touch Type (metric sizes)

Part No.	Diameter × Depth	Part No.	Diameter × Depth	Part No.	Diameter × Depth	Part No.	Diameter × Depth
TK00700	14 × 25	TK00339	20 × 25	TK00347	24.5 × 25	TK00355	31 × 25
TK00701	15 × 25	TK00340	21 × 25	TK00348	25 × 25	TK00356	32 × 25
TK00702	16 × 25	TK00341	21.5 × 25	TK00349	26 × 25	TK00357	33 × 25
TK00703	17 × 25	TK00342	22 × 25	TK00350	26.5 × 25	TK00358	33.5 × 25
TK00335	17.5 × 25	TK00343	22.5 × 25	TK00351	27 × 25	TK00359	34 × 25
TK00336	18 × 25	TK00344	23 × 25	TK00352	28 × 25	TK00360	34.5 × 25
TK00337	19 × 25	TK00345	23.5 × 25	TK00353	29 × 25	TK00361	35 × 25
TK00338	19.5 × 25	TK00346	24 × 25	TK00354	30 × 25		

Jetbroach One-touch Type (metric sizes)

Part No.	Diameter × Depth	Part No.	Diameter × Depth	Part No.	Diameter × Depth	Part No.	Diameter × Depth
TK00301	17.5 × 35	TK00309	21.5 × 35	TK00317	26 × 35	TK00325	33 × 35
TK00302	18 × 35	TK00310	22 × 35	TK00318	26.5 × 35	TK00326	34 × 35
TK00303	18.5 × 35	TK00311	22.5 × 35	TK00319	27 × 35	TK00327	34.5 × 35
TK00304	19 × 35	TK00312	23 × 35	TK00320	28 × 35	TK00328	35 × 35
TK00305	19.5 × 35	TK00313	23.5 × 35	TK00321	29 × 35		
TK00306	20 × 35	TK00314	24 × 35	TK00322	30 × 35		
TK00307	20.5 × 35	TK00315	24.5 × 35	TK00323	31 × 35		
TK00308	21 × 35	TK00316	25 × 35	TK00324	32 × 35		

Jetbroach One-touch Type (metric sizes)

Part No.	Diameter × Depth	Part No.	Diameter × Depth	Part No.	Diameter × Depth	Part No.	Diameter × Depth
TK00380	17.5 × 50	TK00387	21.5 × 50	TK00394	25 × 50	TK00401	31 × 50
TK00381	18 × 50	TK00388	22 × 50	TK00395	26 × 50	TK00402	32 × 50
TK00382	19 × 50	TK00389	22.5 × 50	TK00396	26.5 × 50	TK00403	33 × 50
TK00383	19.5 × 50	TK00390	23 × 50	TK00397	27 × 50	TK00404	34 × 50
TK00384	20 × 50	TK00391	23.5 × 50	TK00398	28 × 50	TK00405	35 × 50
TK00385	20.5 × 50	TK00392	24 × 50	TK00399	29 × 50		
TK00386	21 × 50	TK00393	24.5 × 50	TK00400	30 × 50		



Overseas Affiliates / Offices

NITTO KOHKI U.S.A., Inc.
4525 Turnberry Drive, Hanover Park, IL 60133, U.S.A
Tel:(1)-630-924-9323 Fax:(1)-630-924-0303
http://www.nittokohki.com/index.html

NITTO KOHKI EUROPE Co., Ltd.
Unit 21, Empire Centre, Imperial Way,
Watford Hertfordshire, WD24 4TS, United Kingdom
Tel:(44)-01923-239668 Fax:(44)-01923-248815
http://www.nitto.co.uk/

NITTO KOHKI DEUTSCHLAND GmbH
Lerchenstr. 47, D-71144 Steinenbronn, Germany
Tel:(49)-7157-22436 Fax:(49)-7157-22437
http://www.nitto-kohki.de/

NITTO KOHKI AUSTRALIA Pty. Ltd.
77 Brandl Street, Eight Mile Plains QLD 4113,
Australia
Tel:(61)-7-3340-4600 Fax:(61)-7-3340-4640
http://www.nitto-australia.com.au/

NITTO KOHKI Co., Ltd. Singapore Branch
10 Ubi Crescent #01-62, Ubi Techpark Lobby D,
Singapore 408564
Tel:(65)-6227-5360 Fax:(65)-6227-0192
http://www.nitto-kohki.co.jp/e/nksb/

NITTO KOHKI Co., Ltd. Shanghai Representative Office
#1117 Ruijing Building, Maoming South Road,
Shanghai 200020 China
Tel:(86)-21-6415-3935 Fax:(86)-21-6472-6957
http://www.nitto-kohki.cn/

NITTO KOHKI Co., Ltd. Shenzhen Representative Office
#0726 International Culture Building, 3039, Shennan
Zhong Rd., Futian District, Shenzhen, 518003 China
Tel:(86)-755-8375-2185 Fax:(86)-755-8375-2187
http://www.nitto-kohki.cn/

NITTO KOHKI Co., Ltd. Bangkok Representative Office
38Q, House Convent Bldg, 7th Floor, Unit 7A,
Convent Rd, Silom, Bangkok, 10500 Thailand
Tel:(66)-2-632-0307 Fax:(66)-2-632-0308
http://www.nittobkk.com/eng_index.htm

EC DECLARATION OF CONFORMITY

We hereby declare that the following our product conforms with the essential health and safety requirements of EU Directives.

Product: PORTABLE MAGNETIC DRILLING MACHINE
Model: ATRAA CE : WA-3500
Serial No: XXXXXX XXXX -> year(A.D.)
Consecutive numbers (00001~99999)
Last digit (0-9) of year (A.D.)
Manufacturer: NITTO KOHKI Co., Ltd.
2-9-4, Nakaikegami, Ohta-ku, Tokyo, 146-8555, Japan
Authorised person to prepare the technical construction file(TCF) in the community:
Masatoshi Ogue
President
NITTO KOHKI EUROPE Co., Ltd.
Unit21, Empire Centre, Imperial Way, Watford Hertfordshire,
WD24 4TS, UK
Tel:(44)-01923-239668 Fax:(44)-01923-248815
Directive: 2006/42/EC Machinery Directive
2006/95/EC Low Voltage Directive
2004/108/EC EMC Directive
2011/65/EU RoHS Directive

The above product has been evaluated for conformity with above directives using the following European standards. The technical construction file (TCF) for this product is retained at the above manufacturer's location.

Machinery Directive/ Low Voltage Directive:
EN ISO12100:2010, EN ISO14121-1:2007, EN60204-1:2006, others
EMC Directive:
EMI EMS
EN55014-1:2006 EN55014-2:1997+A1:2001:Category II
EN61000-3-2:2006 EN61000-4-2:1995+A1:1998+A2:2001
EN61000-3-3:1995+A1:2001+A2:2005 EN61000-4-4:2004
EN61000-4-5:1995+A1:2001
EN61000-4-6:1996+A1:2001
EN61000-4-11:2004

RoHS Directive:EN50581
Signature: K.Kishi
Date/Place: Oct. 05. 2012. /Tokyo, Japan
Name: K.Kishi
Title: GENERAL MANAGER MACHINE TOOLS DIV.

NITTO KOHKI Co., Ltd.
2-9-4, Nakaikegami, Ohta-ku, Tokyo, 146-8555, Japan